



LMC Mini – Facer SB^{©™®} USER MANUAL



Issue Year
version 2 - 2016

Design and Manuf
Len Matec prio bvba
WWW.LENMATEC.BE



Introduction

Thank you for purchasing the Mini Facer SB [®]™ [©].

This easy to use manual driven flange facing apparatus is designed to help the user to recondition flange gasket seating area's .

Below User Manual is drawn up to help you operate and maintain the Mini Facer SB [®]™ [©]. in a safe way.

The Manual has 4 chapters , added also are recommendations and drawings thus to foresee in maximum information .

PREFACE

Contains information about the use of this user manual

CONTENCE LIST

1. Introduction

General information about the LMC Mini Facer SB [®]™ [©] , the function and the demands that are requested for the conditions of use and also the operator

2. Safety

Describes the most important safety risc's , safety precautions to follow from the operator / user . also the meaning of the safety symbols on the MinFacer[®]™[©]

3. Transport and Storage

This chapter gives instruction for transport , maintenance and storage of the Mini Facer SB [®]™ [©]

4. Operating the Mini Facer SB [®]™ [©].

Discribes how to use the Mini Facer SB [®]™ [©].

5. Photo's and drawings

Contence

- INTRODUCTION..... 2**
- CONTENCE..... 5**
- 1 INTRODUCTION 4**
 - 1.1 PRODUCT DESCRIPTION 4
 - 1.2 MAINPARTS INDICATION OF THE MINI FACER SB ®™ ©. 5
 - 1.3 CONDITIONS OF USE..... 6
 - 1.4 INSTRUCTIONS FOR THE USER / OPERATOR..... 6
- 2 SAFETY PRECAUTIONS 7**
 - 2.1 INTRODUCTION 7
 - 2.2 APPLICABLE SAFETY PRECAUTIONS TO FOLLOW 7
- 3 TRANSPORT AND STORAGE OF THE MINI FACER SB ®™ ©. 9**
 - 3.1 TRANSPORT 9
 - 3.2 STORAGE 10
- 4 OPERATING THE MINI FACER SB ®™ ©. 11**
 - 4.1 INTRO 11
 - 4.2 MACHINING WITH THE MINI FACER SB ®™ ©. 11
 - 4.3 DIMENSIONS 13

1 Introduction

1.1 Product description

The LMC Mini – Facer[®]™[®] is per definition not a machine but a manual driven tool to obtain flat facing of different type and diameters of flanges .

The Mini Facer SB [®]™[®] . is desgined to do refacing of flat face flanges of various materials.

The tool provides in a gramophone finish thus to create optimum gasket contact and gasket seating conditions.

Due to the integrated feed spindel , which is taking care of the cutting tool feed ,whilst turning the machine and keeping the feed knob , the required surface finish is obtained .

The Mini Facer SB [®]™[®] . is supplied with 2 feed spindles . Standard the ASME B 16.5 Stock finish spindle is mounted . And the other spindle is in the case . Both spindles are engraved on the feed nut .

Mounted spindle :

ASME B 16.5 is for “ stock finish = 6.3 to 12.5 μ m “ according to ASME specification

In the case

the Spindle “ Smooth finish =3.2 to 6.3 μ m “ . this finish is used for other types of gaskets

These surface conditions are commonly used in flange face finish .



For special surface finish requirements we can supply specific tooling please contact your dealer for info and or availability .

The Mini Facer SB [®]™[®] . has a yellow/gold color body finish , to improve visibility this body carries a unique serial nr engraved into the body of the tool below the tekst “ LMC Mini Facer[®]™[®]

The Mini Facer SB [®]™[®] is delivered in a sturdy carry case with slotted pockets to store components from the tool .

The internal clamping diameter range of the LMC Mini – Facer SB[®]™[®] is From +/- 1/2” to 1 1/4 ” => 13,5 mm to 30,5 mm (with the std supplied collets)



The facing diameter rage of the LMC Mini-Facer SB [®]™[®] is from 1” – to 14” => 13,5 mm to 355 mm

1.2 Mainparts indication of the Mini Facer SBTM ©

De LMC Mini – Facer[®] is built from a number of principle parts , indicated on below picture.

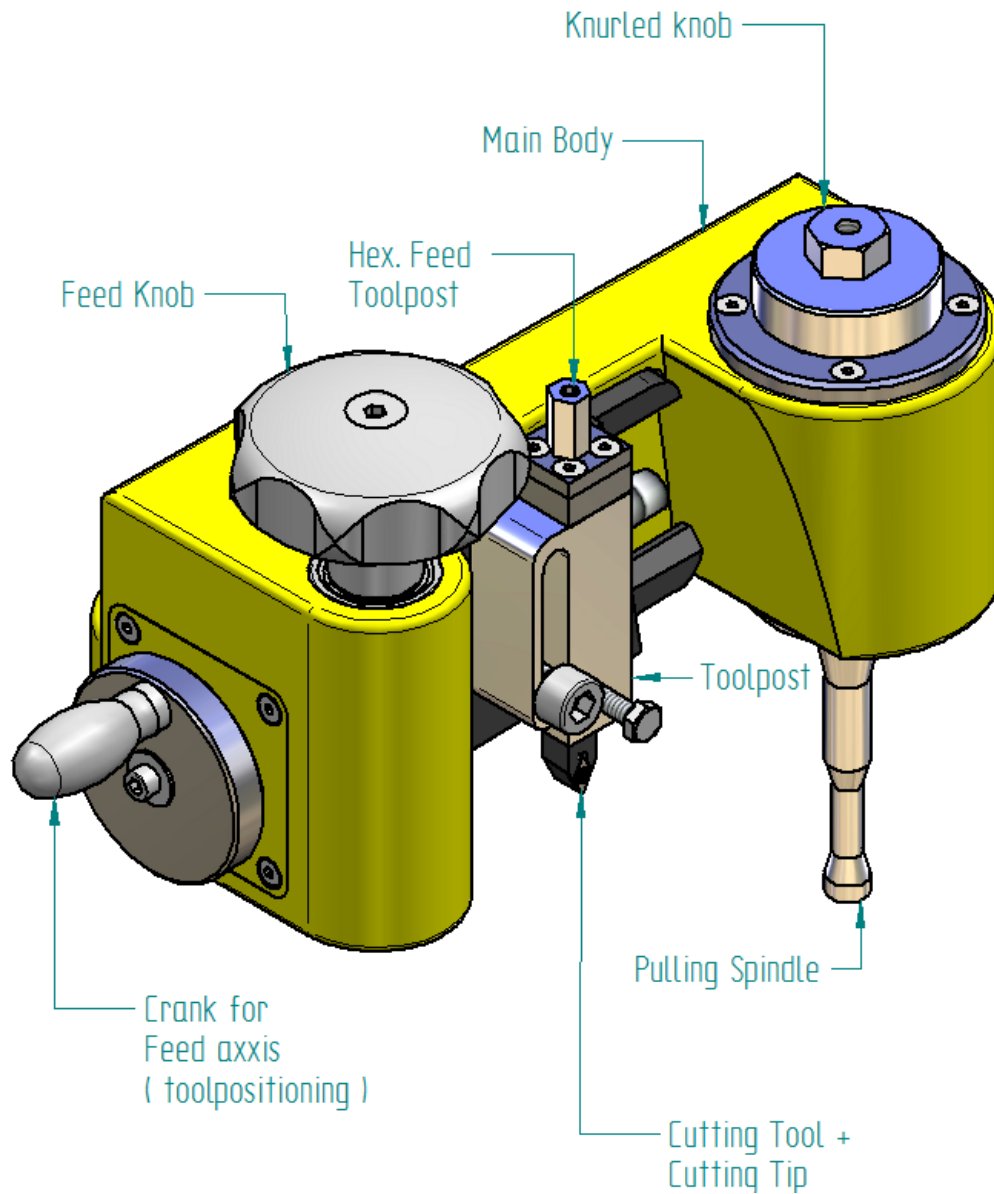

1.3 Conditions of use

The Mini Facer SB [®]™ [®] shall only be used in the following conditions . .

- Make sure the operator / user of LMC Mini – Facer SB[®]™[®] has read and understood the User Manual
- All Safety precautions are fulfilled .
- There is no damage to the LMC Mini – Facer SB[®]™[®]
- No other condition to disturb normal working of the Mini Facer SB [®]™ [®] applies .
- Maintenance and cleaning shall be taken care off and respected before all use .

1.4 Instructions for the user / operator



The LMC Mini – Facer SB[®]™[®] shall only be used by operators that are fully instructed and confident with the operation . Further more it is obligatory to wear in all conditions of use the necessary safety garments and clothing , such as : safety clothing , shoes , goggles . Avoid to wear loose clothing.

2 Safety precautions

2.1 Introduction

In this chapter the safety precautions are treated every operator using the Mini Facer SB [®]™ © shall follow these instructions in full . .



If there is any safety aspect unclear please check the Users manual or ask for more information from the safety advisor or from your dealer .

In certain cases , specific additional safety precautions might apply . Please inform and apply these instructions .

2.2 Applicable Safety precautions to follow

For a safe use of the LMC Mini – Facer SB[®] it is required to respect a number of precautions . Thee are stipulated below ..

Personal protection :

- We advise to wear Safety shoes , safety goggles , gloves and applicable work clothing during the use of the LMC Mini – Facer[®].



- Assure that all setting components or loose elements (e.g. the grippers the cutting toolholder) of the Mini Facer SB [®]™ © are tightened or fixed the way they should be .
- Check that there are no external damages on LMC Mini – Facer SB [®]™ © .
- Assure that the piping you work on is fully safe to work at and no dangerous and harmful products are present .
- Always work in the most ergonomical way . Thus to avoid injuries from the back or other inconvenient problems of health . .
- Also assure people in the direct surrounding wear the necessary personal protection means
- Check before starting to operate that there is no obstacle that can cause injury or damage to the Mini Facer SB [®]™ ©.
- Also assure that the operators fysical condition is okay to do this kind of work in the conditions that apply during the work ;

Safety measures during the use of the Mini Facer SB [®]™ [®] ©

- Wear the prescribed personal protection means during the use .
- E.g. Safety goggles , working clothing , safety boots , etc etc

- The wear of tight fit long sleeve working clothes is required since the swarf can be very warm and sharp , thus might cause injury .

- Make sure the collet is always firmly tightened so that the Mini Facer SB [®]™ [®] © does not come loose during the turning operation .



Do not wear loose garment , jewelry(such as rings etc) or loose hair during the work. These can cause jamming of fingers or other injuries and might lead to other dangerous situations ..

Note: Before every use of the Mini facer make sure no dirt, swarf or other components can fall into the flange bore (pipe).

3 Transport and Storage of the Mini Facer SB[®]™[®] ©

3.1 Transport

De LMC Mini – Facer[®] is supplied in a sturdy hard plastic compact carry case .
This sturdy carry case is suitable for the transport of the Mini Facer SB[®]™[®] ©.

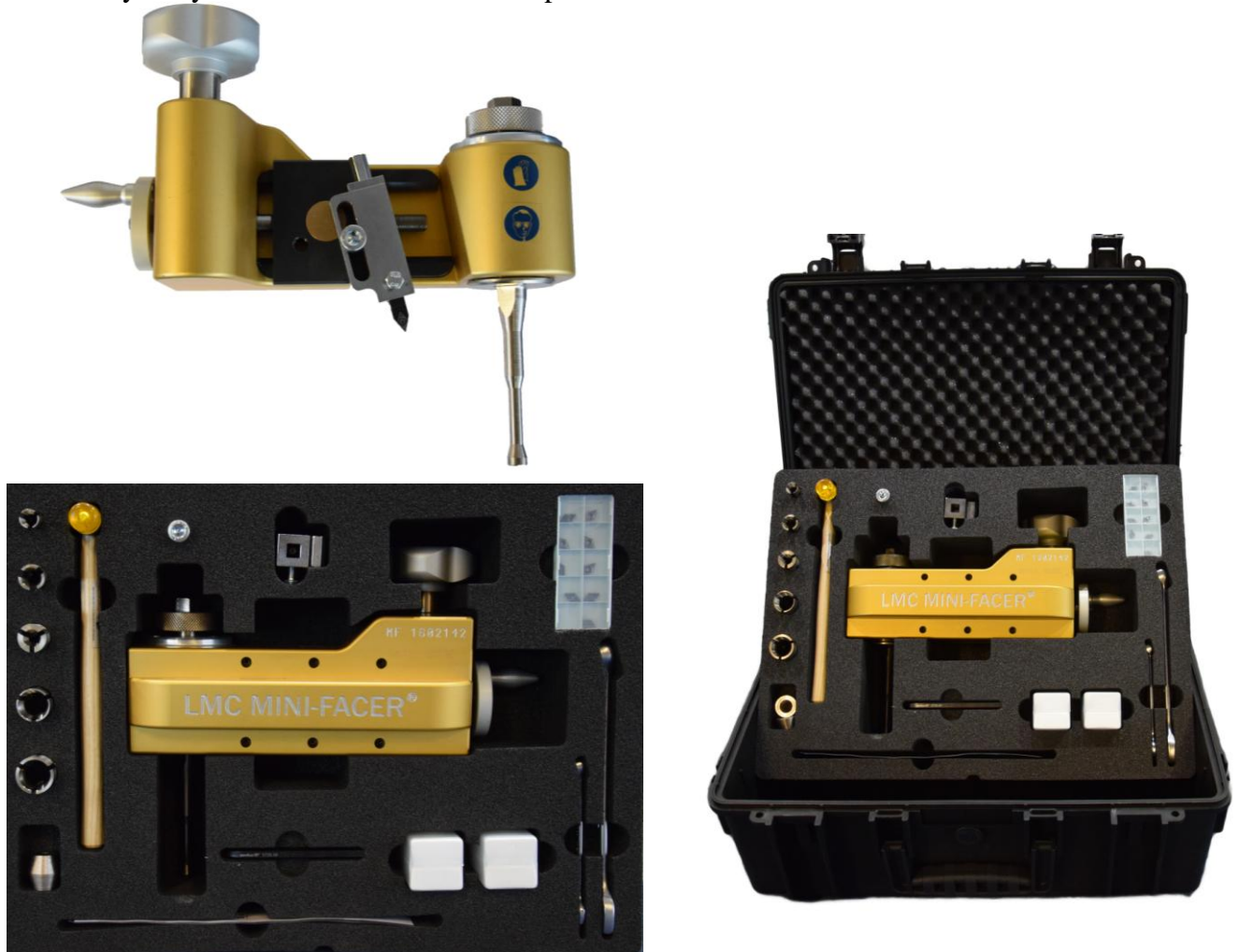

Do assure that the latches at the front of the carry case are firmly closed before lifting ,
moving, manipulating or carrying the case .

To protect the outside shell of the carry case , it is recommended to cover the case in a bubble
film or full covering box when shipping .

shipping data : - dimensions : (23 x 43 x 52) cm
 - weight : 15 kg.

Check after every transport that the case is intact and no damage has occurred .

In case of any damage ,replace the carry case for safety reasons and to avoid loss of tooling.
All periferical tooling is also in this carry case . All tooling has a proper place in the box (
cutout spaces foreseen) and is therewith clearly visible for the user .



During transporting the Mini Facer SB[®]™[®] case shall be fixed as load . Never
put any heavy stuff on the Mini Facer SB[®]™[®] thus to avoid damage of the tool
and the carry case .

3.2 Storage

- **Always store the Mini Facer SB[®]™[©] in a dry and clean place .**
- After every use dry and clean the Mini Facer SB[®]™[©] with a clean cloth. Make sure that there is no swarf or metal particles in or at the Mini Facer SB[®]™[©] because they can disturb the clamping as well as the movement for normal operation . Remove the clamping spindle out of the hollow center shaft center , clean , inspect and lubricate slightly with a smooth film of spindle oil and put back into position.
- Then inspect to tool for eventual damage or loose parts (e.g. bolts) etc (If any loose parts repair or send to your agent for repair)
- After cleaning and inspection , lubricate the slides and spindle with a film of spindle oil, never use WD 40 or similar .
- If stored for long term , then spray the mini facer with a protective spray layer such as Molykote 321D . Never use WD 40 or similar.

4 Operating the Mini Facer SB[™]®

4.1 Intro

Operating the Mini Facer SB[™]® is very simple . Though it is of great importance to respect and apply all safety precautions .

4.2 Machining with the Mini Facer SB[™]®

- 1) Fit the correct spindle for the required surface finish in the Mini Facer SB[™]® (stock finish or Smooth finish)
- 2) Check if the inside diam of the flange to machine is clean and does not show any obstruction or other elements that can disturb correct clamping of the gibs, or center shaft).
- 3) Measure the “id” of the flange and select the correct collet for the diameter of the flange to machine . Use hereby the collet selector chart.
- 4) Turn the knurled knob of the pulling spindle and place the collet on the pulling spindle

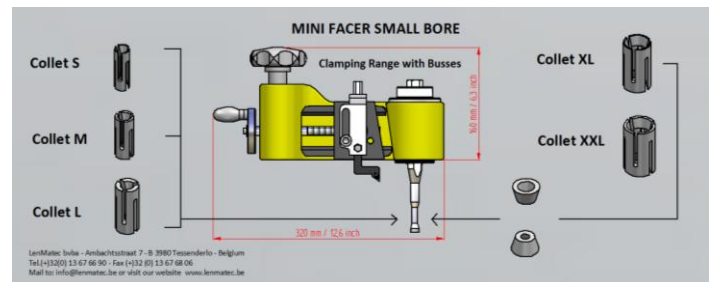

Collet selector chart

Collet name	Min clamping	Max clamping
Small (S)	Ø 13,5 mm Ø 0,531 inch	Ø 16,5 mm Ø 0,649 inch
Medium (M)	Ø 16,5 mm Ø 0,649 inch	Ø 19,5 mm Ø 0,767 inch
Large (L)	Ø 20,5 mm Ø 0,807 inch	Ø 23,5 mm Ø 0,925 inch
Extra large (XL)	Ø 24 mm Ø 0,944 inch	Ø 27 mm Ø 1,062 inch
Extra extra large (XXL)	Ø 27,5 mm Ø 1,082 inch	Ø 30,5 mm Ø 1,181 inch

Len Matec
bvba

- 5) Turn the knurled knob on the pulling spindle.
- 6) The Mini Facer SB [®]™ [©] is now ready to be fit into the bore of the flange.
- 7) Place the center shaft with the clamping set into the bore of the flange , keep the fingers around the clamping shaft and smoothly slide the collet down into the bore . Position the collet 2 mm lower then the face of the flange .
- 8) Turn the knurled knob clockwise so the collet go out and start to clamp into the bore. While turning the knob slightly move the Mini Facer SB [®]™ [©] so that the centering is optimal. When the Mini Facer SB [®]™ [©] is in place , then use the 19 mm spanner (on the HEX on top of the knob) to firmly tighten the Mini Facer SB [®]™ [©] in place .
- 9) Place the cutting tool into the toolpost . Check the cutting tip and replace if necessary. Assemble the toolpost onto the toolslide so that the cutting tip faces towards you.
- 10) Now lift the turning (Alu knob with finger indentions) to disengage the feed and position the cutting tool with the crank towards the inside of the flange to face.
- 11) Stop in the middle , release the fixing bolt on the toolpost , and feed down the cutting tool so that it just contacts the metal face . Then tighten the fixing bolt on the toolpost again. Position the cutting tool further inwards , until it has gone over the metal to machine (I.e. in a position that it is free)
- 12) Now engage the feed by pushing the Alu knob down . Grab the Alu knob with your hand and turn round counter clock wise . The feed system will now move the cutting tool automatically from inside to outside.

Important notice :

DO NOT STOP TURNING WHEN THE CUTTING TOOL IS MACHINING AND NEVER TURN INTO THE OPOSITE DIRECTION .

Otherwise the surface finish is not even and the cutting tip might break of

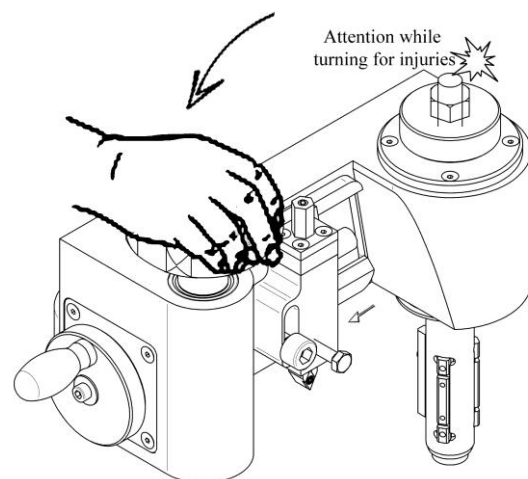

If the whole area is not touched , then lift the aluminium knob again , turn the cutting tip to the inside , release the fixing bolt on the toolpost , turn the cutting tip down for 1/12 revolution (equals +/- 0.1 mm down feed) And repeat the machining operation . Repeat this until the whole gasket area is done .

Turn until the cutting tip is over the metal to machine (outside the gasket face)

- 13) When the operation is done and the gasket face is evenly machined , the job is ready
- 14) To take the Mini Facer SB [®]™ [©] out of the flange , remove the toolpost (Alan bolt) , then release the hex (19 mm) center knurled knob . Then support the Mini Facer SB [®]™ [©] with your one hand and , tap the center shaft with the plastic hammer . then the collet will come loose and the Mini Facer SB [®]™ [©] can be taken out of the bore .

4.3 Dimensions

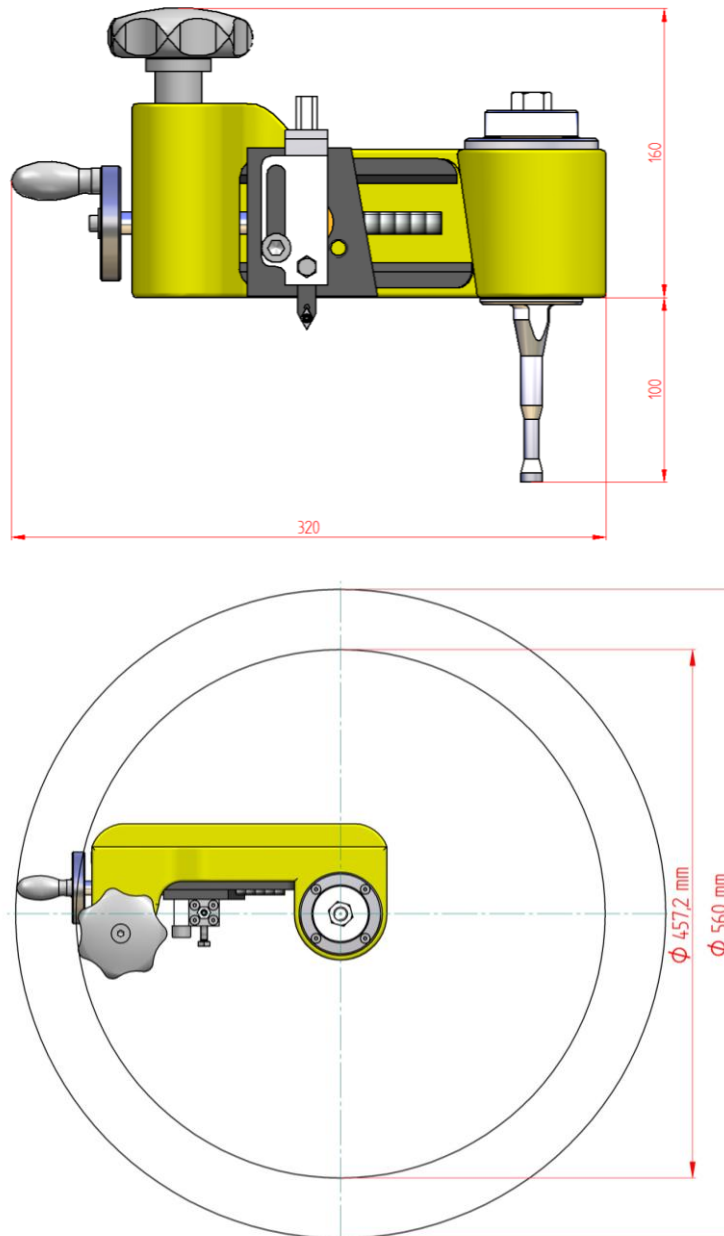

Please ask your distributor for more info if you find any problem operating the Mini Facer SB [®]™ [©].